



INSTALLATION INSTRUCTIONS FOR THE UNIDEN R3 RADAR DETECTOR

PLEASE READ THESE INSTRUCTIONS THOROUGHLY BEFORE INSTALLING THIS MOUNT  
WE RECOMMEND INSTALLING THIS MOUNT FROM THE PASSENGER SIDE OF THE VEHICLE



RECOMMENDED



SCAN FOR INSTALL VIDEO OR  
VISIT [BLENDMOUNT.COM/CHEVROLET/C8](http://BLENDMOUNT.COM/CHEVROLET/C8)



OPPOSING FORCES



RADAR DETECTOR  
RELEASE  
BUTTON

SPRING CLIP  
RELEASE TAB

1 - Install and remove your radar detector (RD) onto the mount before installing it on the rear view mirror so you can observe how the spring clip functions. To release tension from the spring clip, simply squeeze the release tab and the back side of the mount together as shown above. This will lower the bottom portion of the spring clip allowing you to slide the RD on and off the mount. To install the RD, squeeze the release tab and slide the clip into the RD until it locks into position. To remove the RD, squeeze the release tab with one hand and press the RD release button with the other hand. **Once the RD slides about 1/8" you can let go of the RD release button and slide the RD off of the spring clip.** When used properly, the spring clip avoids putting excessive pressure on the mirror stem when installing and removing the RD.

DO NOT REMOVE MIRROR FROM VEHICLE  
IMAGES BELOW ARE FOR ILLUSTRATION PURPOSES ONLY

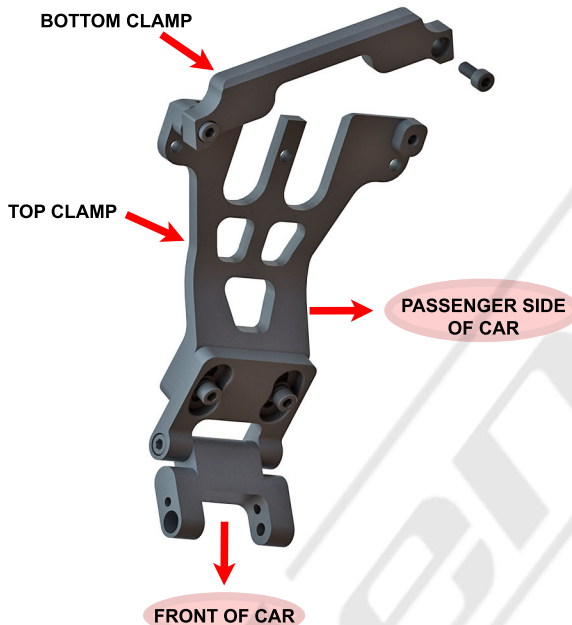

BOTTOM CLAMP

TOP CLAMP

PASSENGER SIDE  
OF CAR

FRONT OF CAR

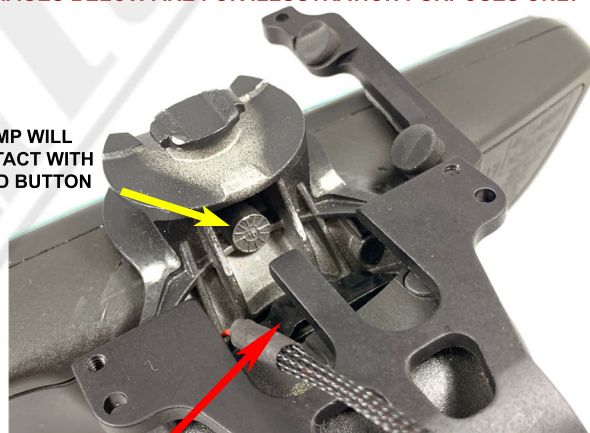

TOP CLAMP WILL  
MAKE CONTACT WITH  
THIS ROUND BUTTON

OPEN CHANNEL FOR (OPTIONAL)  
MIRRORTAP POWER CORD  
CLEARANCE

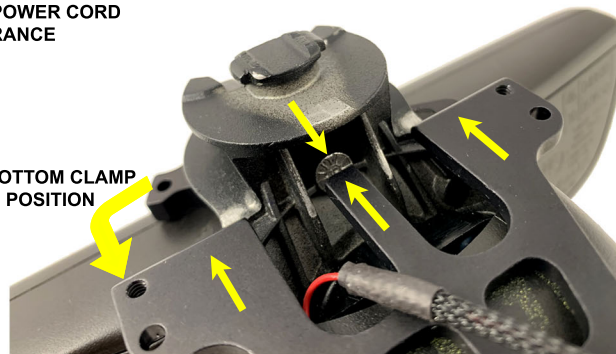

SWING BOTTOM CLAMP  
INTO POSITION

2 - We recommend sitting in the passenger seat when installing this mount and placing a towel over the dashboard. **If you are installing a MirrorTap Power Cord to power your radar detector, it needs to be installed before installing this mount.**

Remove the bolt from the right side of the bottom clamp and loosen the left bolt 2-3 revolutions as shown above. Swing the bottom clamp approximately 90 degrees towards the driver's side which will allow you to slide the mount between the headliner and the top of the mirror.

3 - The 2 pictures above show you what you can not see when you are installing this mount. Before sliding the Top Clamp into position, make sure the MirrorTap Power Cord is positioned within the open channel of the top clamp as shown above. Push the top clamp towards the rear of the vehicle trying to keep it somewhat centered left to right. The top clamp will wedge between the mirror and the headliner as you are pushing rearward until it makes contact with the round button of the mirror as shown above. Rotate the bottom clamp back to its home position and reinstall the bolt. Tighten the bolt 2-3 revolutions.



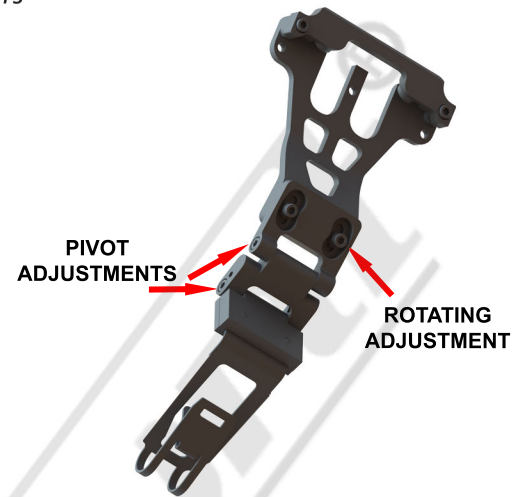
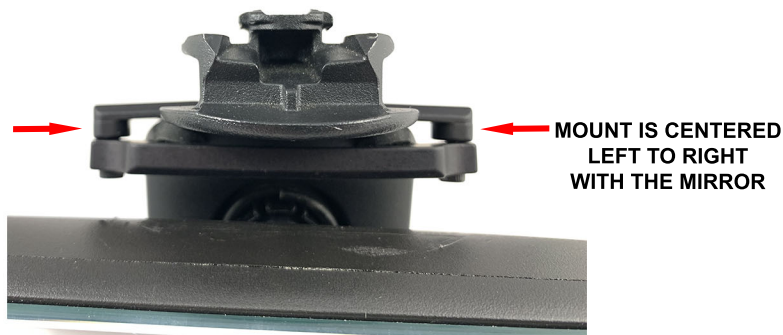

**4 -** At this point, both Clamp Bolts should be loose which will allow you to move the mount from side to side until it is centered with the top of the mirror as shown above. When the mount is centered, start to tighten both of the Clamp Bolts. Move the mirror if necessary to access the bolts with the long allen wrench provided. Tighten one bolt 1-2 revolutions and then tighten the other bolt 1-2 revolutions as well. Keep alternating tightening the bolts until they are both fully tightened as tight as you can make them. You will notice the 2 rubber pads will compress as you are tightening. The rubber pads will protect the mirror from getting scratched.

**5 -** Install your radar detector onto the mount. Use the adjustments shown above to adjust the RD to your desired position. We recommend adjusting the mount so the V1 is as close to the bottom of the mirror as possible keeping in mind that when the V1 is removed it will slide under the mirror. When the rotating adjustment is used to rotate the RD towards the driver, the footprint of the RD is reduced. Be sure to securely tighten all of the adjustment bolts after the adjustments are made. This mount is made of aircraft grade aluminum so you can securely tighten all of the bolts without stripping the aluminum.

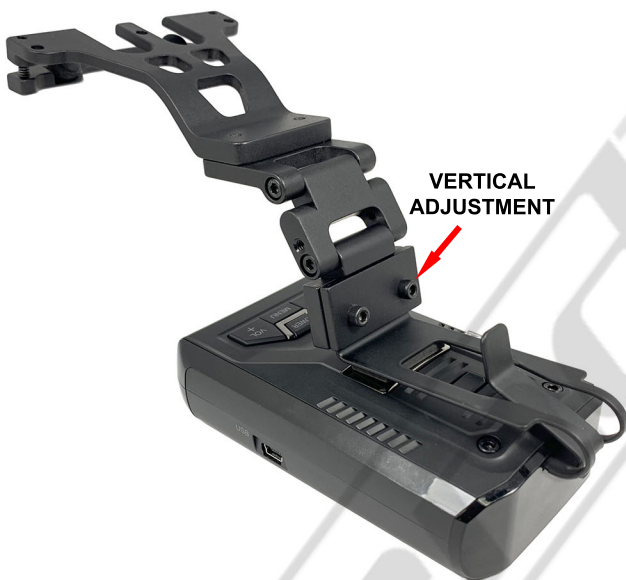

FOR MORE INFO VISIT [www.blendmount.com/videos](http://www.blendmount.com/videos)

**CAUTION**

**DO NOT** use this mount if it interferes with the adjustability or the operation of your rear view mirror in any way.

**DO NOT** use this mount if the radar detector creates an unsafe viewing obstruction.

**DO NOT ATTEMPT TO MODIFY THIS PRODUCT.** Consult the manufacturer for assistance.

All BlendMount products are accompanied with detailed installation instructions and adjustment tips. You are encouraged to contact [customerservice@blendmount.com](mailto:customerservice@blendmount.com) or call J28 Design at 1-888-497-8388 for further assistance.

Check the BlendMount Forum for installation tips and some vehicle specific installs.  
[www.blendmount.com](http://www.blendmount.com)

Your feedback is very important to us. Please email any questions or comments you have to [customerservice@blendmount.com](mailto:customerservice@blendmount.com)



**Innovative Design And Precision Manufacturing**

BlendMount - US PATENT # D625,580 S, D656,811 S, D653,980 S, D690,245 S, D690,246 S, D690,247 S and other patents pending